

BE-GE 2600 Airsuspended

SE

SE



Available in SE
(Forestry/Construction)



Cushion angle
adjustable 16°



Backrest adjustable 40°



90 mm height adjustment



Front edge adjustment



Seat at the picture:
BE-GE 2600SE Airvent with headrest

Be Seated by



Förarmiljö ab

Enjoy the comfort

At your service since 1987

BE-GE 2600 Air suspension, designed to give the driver maximal comfort in rough environments.

BE-GE 2600 Air suspension has easy and quick adjustments

Seats with mark are designed for Forestry/Construction area tough conditions in today's working environments. -seats with sliding track round bar and rheostatically controlled heating element.

BE-GE 2600 Air suspension also available in Airvent design with fans mounted in seat and back cushions. Fans in seat and back cushions can be separately controlled for maximal comfort.

BE-GE 2600 Air suspension can be equipped with many different accessories like: armrest, headrest, safetybelt, extra sidesupport, planedamper, seatpost, tilt, built in compressor etc.

Art no:	Description:
4826.00	BE-GE 2600 Air suspended, air adjustable lumbar support, front edge adjustment, protective bellow and sliding track standard.
4876.24	BE-GE 2600 Air suspended Airvent, element heating, air adjustable lumbar support, front edge adjustment, protective bellow and sliding track standard.
5826.24	BE-GE 2600SE Air suspended, element heating, air adjustable lumbar support, front edge adjustment, protective bellow and sliding track round bar.
5876.24	BE-GE 2600SE Air suspended Airvent with element heating, air adjustable lumbar support, front edge adjustment, protective bellow and sliding track round bar.

	Standard	
A	300	325
B	200	225
C	220	245
D	105	80
E	55	100

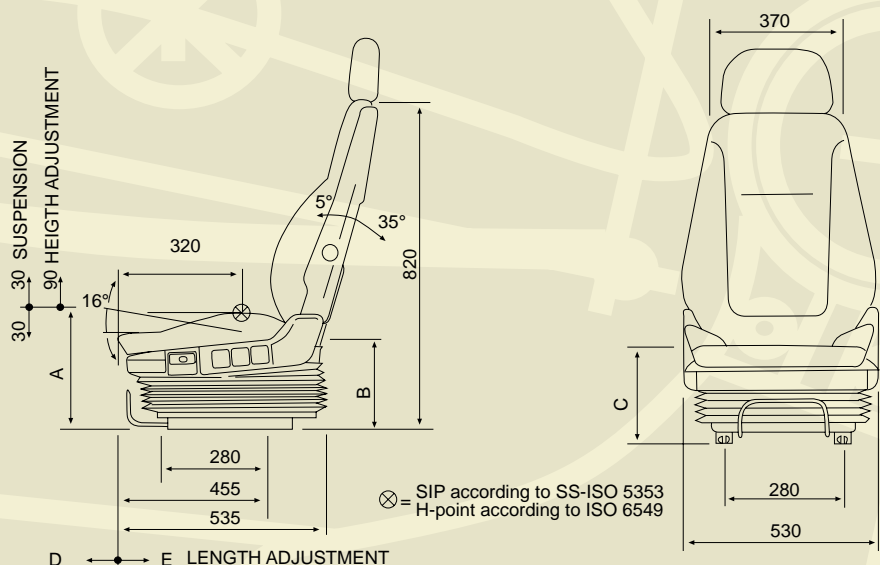

All measurements in mm



Box 7, S-731 10 KOLSVÄ, Sweden
 Tel. +46-(0)221-535 00, Fax +46-(0)221-500 00
www.forarmiljo.se - info@forarmiljo.se